



Rewarding Learning

General Certificate of Secondary Education
2024

Physics

Unit 3 Practical Skills

Booklet B

Higher Tier

MV24

[GPY34]

MONDAY 24 JUNE, MORNING

Time

1 hour 15 minutes, plus your additional time allowance

Instructions to Candidates

Write your Centre Number and Candidate Number in the spaces provided at the top of this page.

You must answer the questions in the spaces provided.

Do not write on blank pages.

Complete in black ink only.

Answer **all** questions.

Information for Candidates

The total mark for this paper is 70.

Figures in brackets printed at the end of each question indicate the marks awarded to each question or part question.

Blank Page

(Questions start overleaf)

- 1 (a) The diagram shows some liquid in a measuring cylinder. The numbers on the scale are in cubic centimetres (cm^3). Two students are asked to measure the volume of liquid in the measuring cylinder.

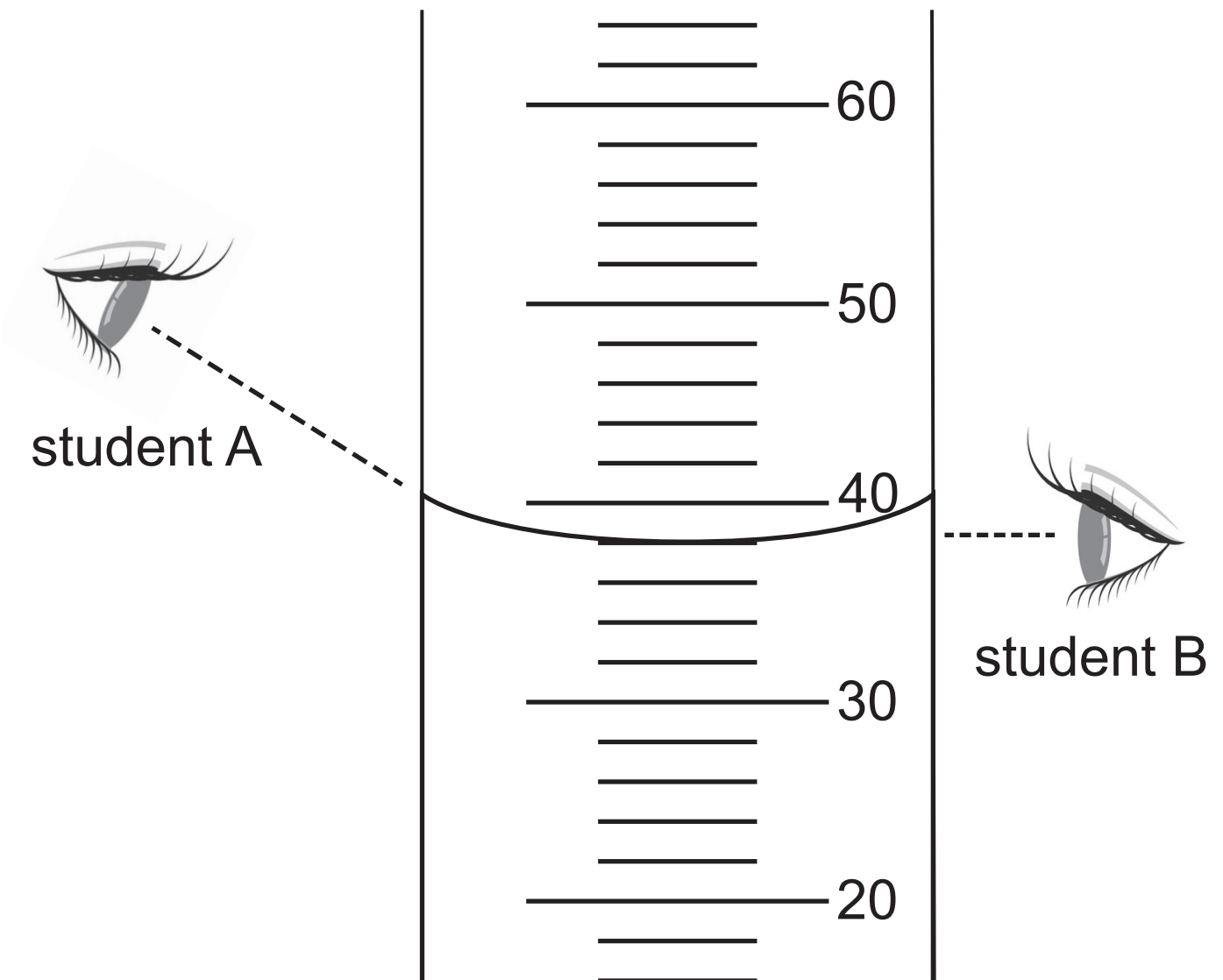

(i) What volume does the smallest division on the scale of the measuring cylinder represent? [1 mark]

_____ cm³

(ii) Which one of the two students is reading the volume of liquid correctly? [1 mark]

Explain your answer.

(iii) What volume of liquid is shown in the diagram opposite? [1 mark]

_____ cm³

(b) A student is asked to investigate how the mass of a liquid varies with its volume. He placed a measuring cylinder on electronic scales as shown below and added different volumes of the same liquid. He recorded the **total mass of the measuring cylinder and the liquid.**

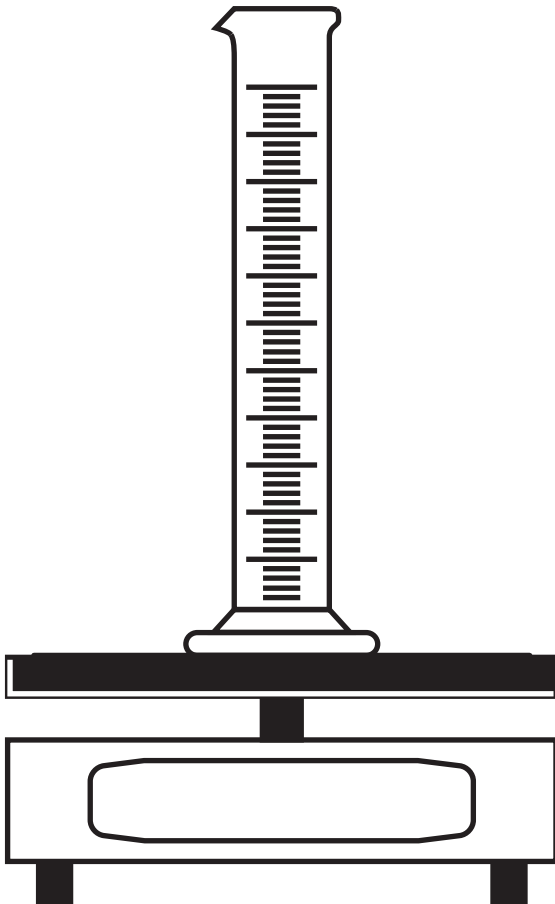

(i) In this investigation name the following. [3 marks]

The dependent variable

The independent variable

The control variable

The results are shown in the table below.

Volume of liquid/cm³	Mass of measuring cylinder and liquid/g
10	48
20	56
30	64
40	72
50	80

(ii) On the grid opposite, plot a graph of the volume of liquid (x-axis) and mass of measuring cylinder and liquid (y-axis).

Label each axis with the quantity and its unit.

Mark each point clearly using × or ⊙.
Draw the best fit straight line through the points. [5 marks]

(iii) Using your line of best fit through the points, determine the mass of the measuring cylinder. [2 marks]

Mass of measuring cylinder = _____ g

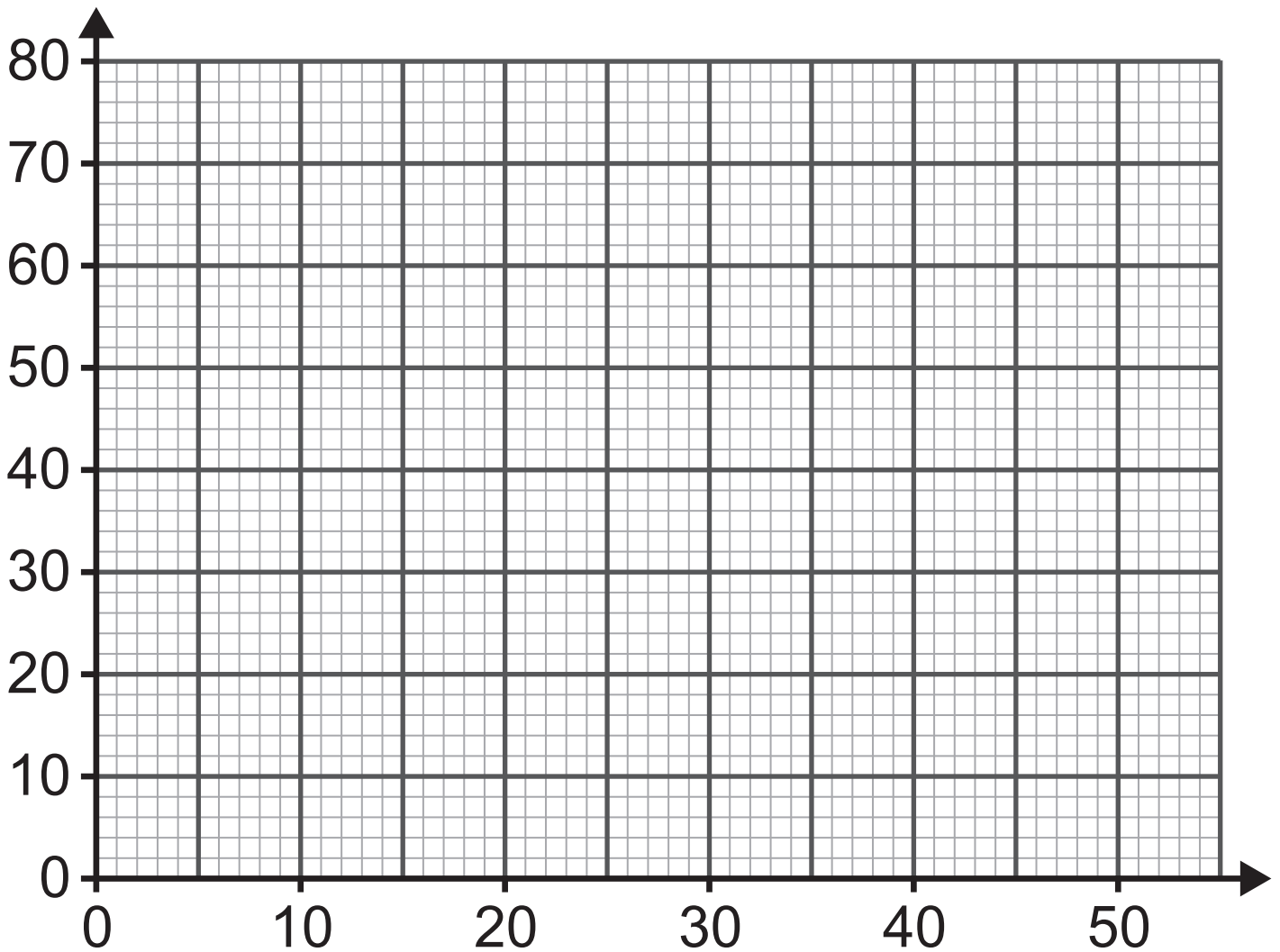

(iv) Using your answer to part **(iii)** and values from the table, calculate the density of the liquid. [5 marks]
Include the unit for density with your answer.
Show clearly how you get your answer.

Density of liquid = _____

Unit = _____

2 A student is planning to carry out an experiment to determine his personal power. His plan is to perform a number of step-ups onto a platform.



(a) Name the piece of apparatus required to measure [2 marks]

the height of the platform

his body mass _____

(b) The diagram below shows the student's mass in kg.

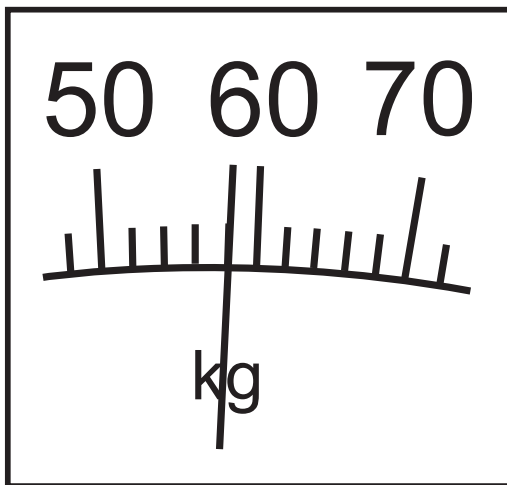

(i) Using the information above, calculate the **weight** of the student.
[3 marks]

Weight = _____ N

The height of the platform is **125 mm**.

(ii) Using your answer to part **(i)** and the equation below, calculate how much work the student does doing **50** step-ups. [5 marks]

Include the unit for work with your answer.

Show clearly how you get your answer, starting with the equation you plan to use.

Work = Force \times Distance

Work done = _____

Unit for work = _____

Another student measures how long it takes her to do 50 step-ups. She measures her time as **25 seconds**. This student does 4000 J of work.

(iii) Calculate the student's personal power. [4 marks]

Include the unit for power with your answer.

Show clearly how you get your answer, starting with the equation you plan to use.

Personal power = _____

Unit of power = _____

(c) How could the result be made **more** reliable? [1 mark]

(d) An alternative method to find personal power involves timing a student running up a flight of stairs.

Two students take exactly the same time to run up this flight of stairs.

Explain why the personal power of these students may not be the same.

[1 mark]

- 3 (a) (i) The image as seen in a plane mirror is described as virtual.
Explain what this means. [1 mark]

- (ii) On the diagram below, mark with an \times the position of the virtual image of the object. [1 mark]

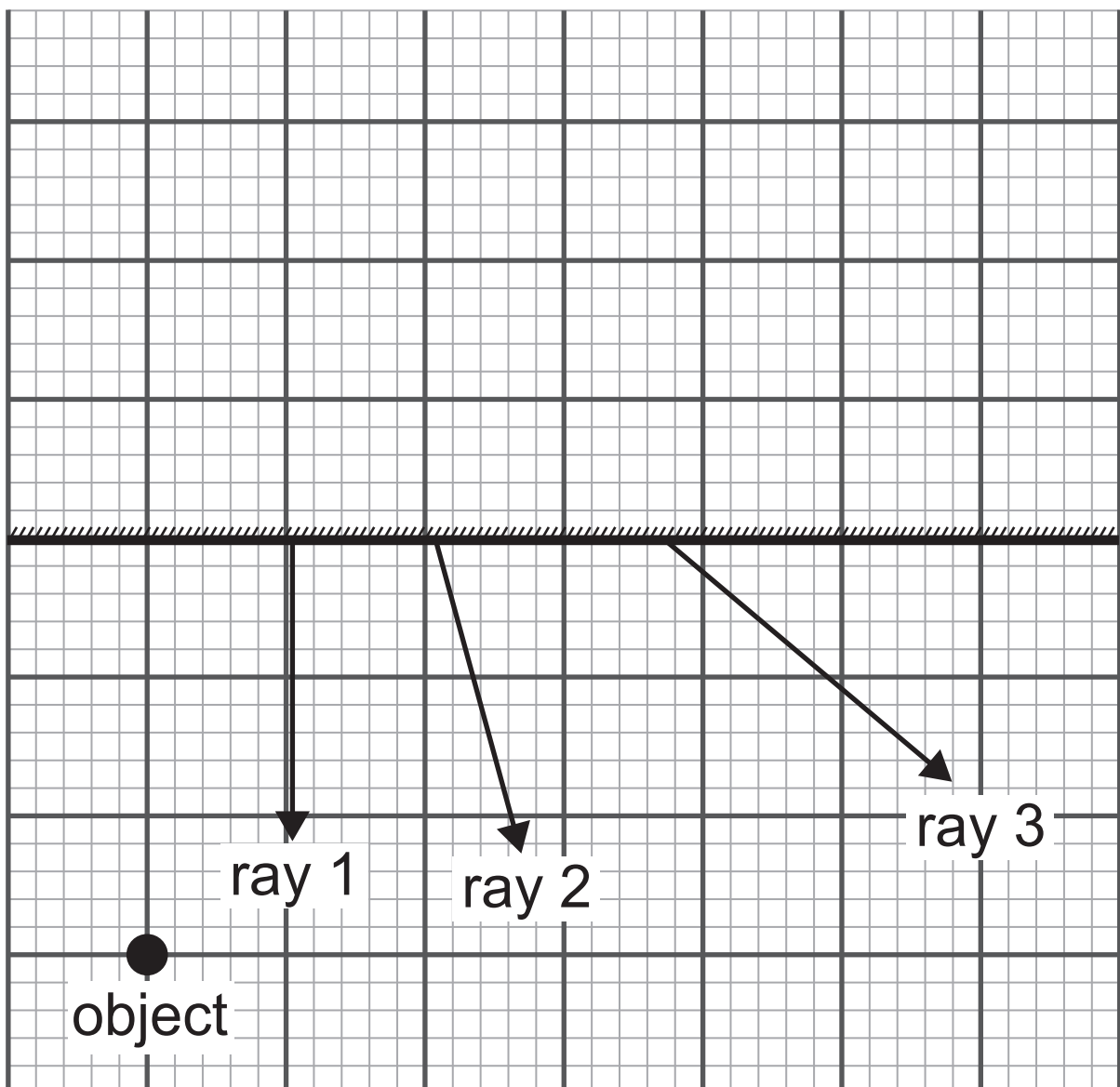

(iii) The diagram also shows three rays of light.

Using your answer to part **(ii)**, decide which ray is the one correctly reflected by the plane mirror.

[2 marks]

Show clearly on the diagram how you obtained your answer.

Ray _____

Explain your answer.

(b) The diagram below shows a ray of light as it passes from air into a rectangular glass block and out into air again.

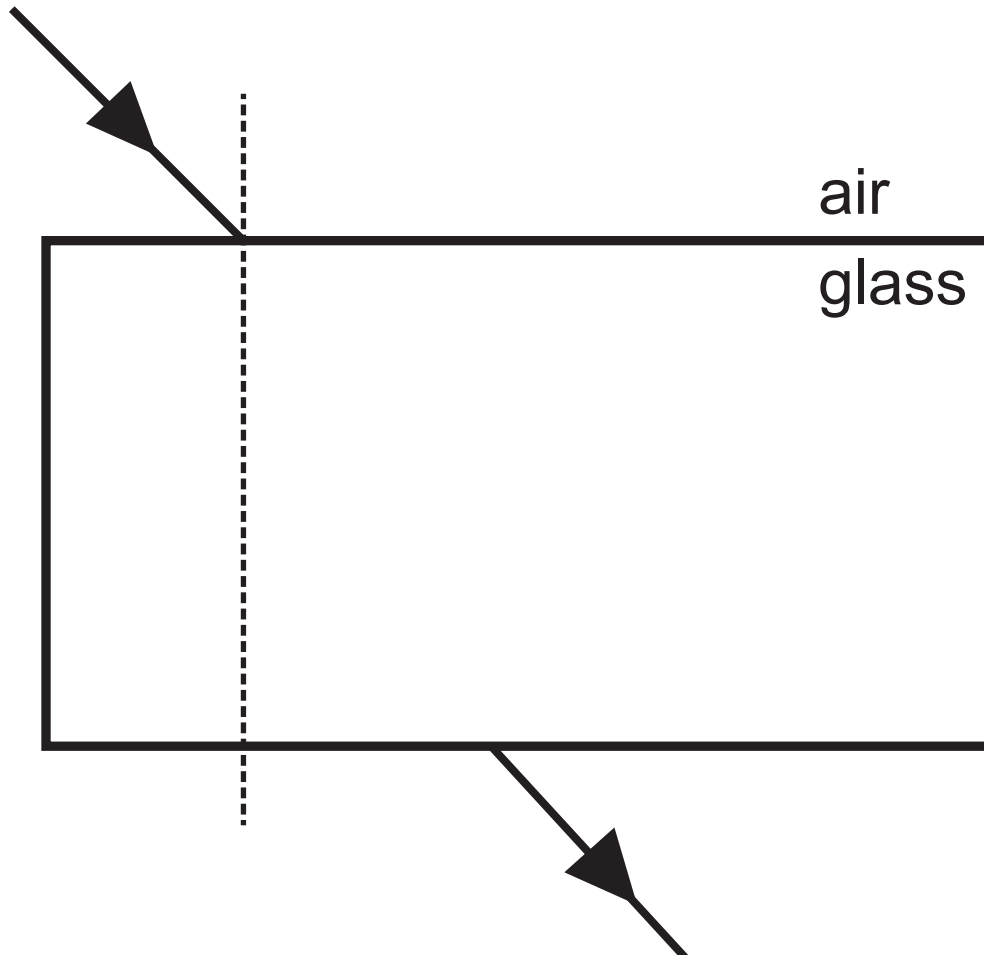

On the diagram, as the ray enters the glass block:

(i) complete the path of the refracted ray through the glass block. [1 mark]

(ii) as light enters the glass block mark
with an **i** the angle of incidence and
with an **r** the angle of refraction.
[1 mark]

A student investigates how the distance D depends on the angle of incidence. The results are shown in the table opposite.

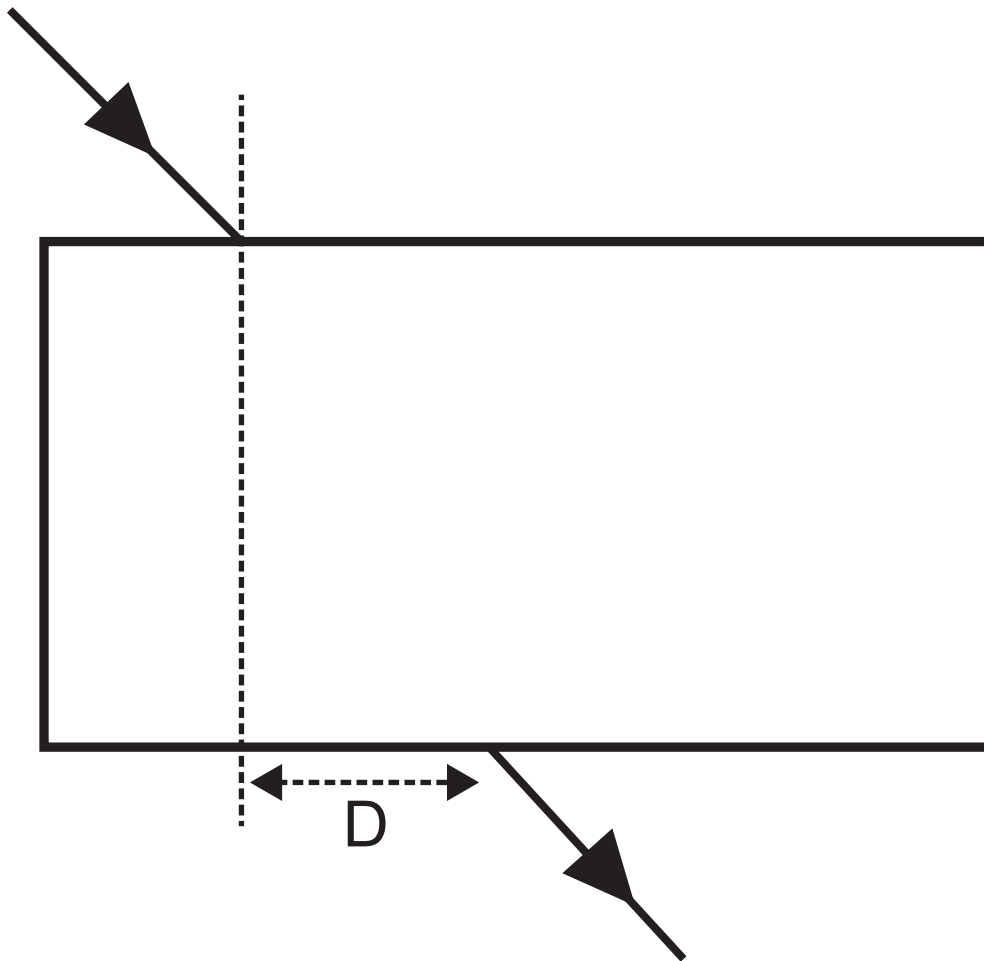

Angle of incidence/°	Distance D/cm
0	0
10	1.0
20	2.5
30	3.5
40	5.0
50	6.0

(iii) On the grid opposite, plot a graph to show how the distance D depends on the angle of incidence.

Use the x-axis for the angle of incidence and the y-axis for the distance D .

Label each axis with the quantity and its unit.

Mark your points clearly using \times or \odot . Draw the best fit straight line through the points. [6 marks]

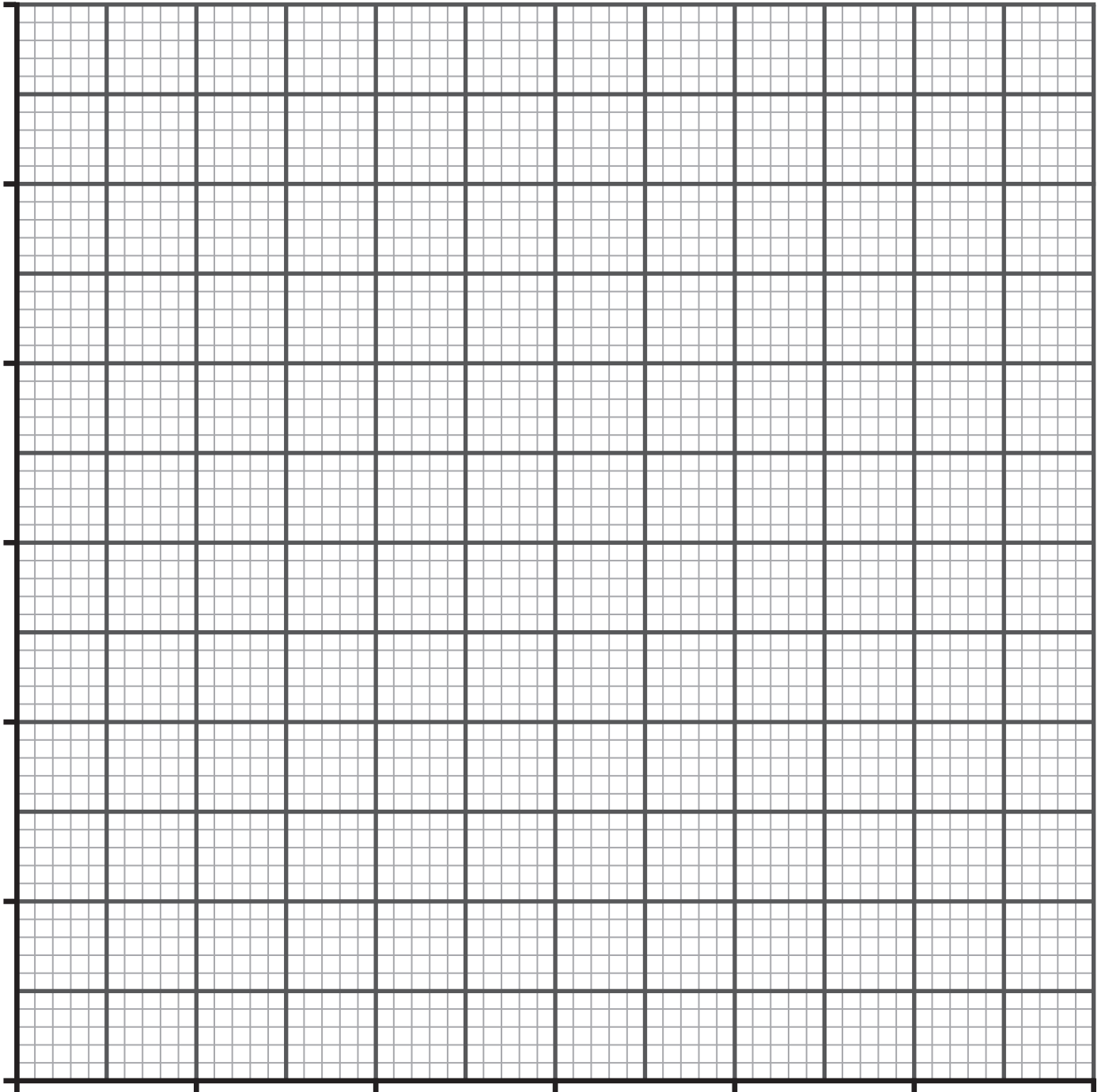

(iv) The graph suggests that the distance D and the angle of incidence i are proportional. The equation below shows the relationship between D and i .

$$D = mi$$

Using the graph, find the value of m .
[4 marks]

Include the unit for m with your answer.

Show clearly how you get your answer.

$$m = \underline{\hspace{10em}}$$

$$\text{Unit of } m = \underline{\hspace{10em}}$$

Blank Page

(Questions continue overleaf)

(c) To show the refraction of light by a semi-circular glass block, the equipment shown below was used. A ray of light from a ray box was passed through the semi-circular glass block.

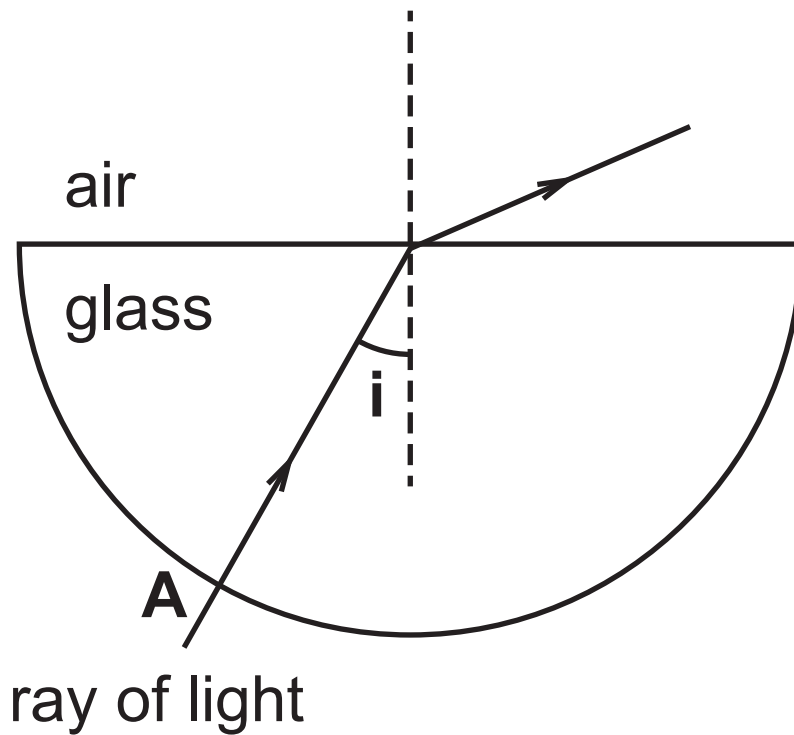

(i) Explain why the incident ray is **not** refracted when it enters the glass block at **A**. [1 mark]

(ii) On the diagram, mark the angle of refraction with the letter **r** for the ray of light as it leaves the semi-circular glass block. [1 mark]

(iii) One ray is missing from the diagram opposite. Carefully add this missing ray to the diagram. [2 marks]

(iv) The angle of refraction was measured as the angle of incidence i was increased. The results are shown in the table below.

Angle of incidence/ $^{\circ}$	0	10	20	30	40	45	50
Angle of refraction/ $^{\circ}$	0	15	32	50	85	No refracted ray seen	No refracted ray seen

Explain why **no** refracted ray was seen when the angle of incidence **i** was 45° and 50° . [1 mark]

- 4 (a) The circuit shown below was built to find the value of the resistance of a resistor. Readings on the ammeter and voltmeter are shown below and opposite. [1 mark for each]

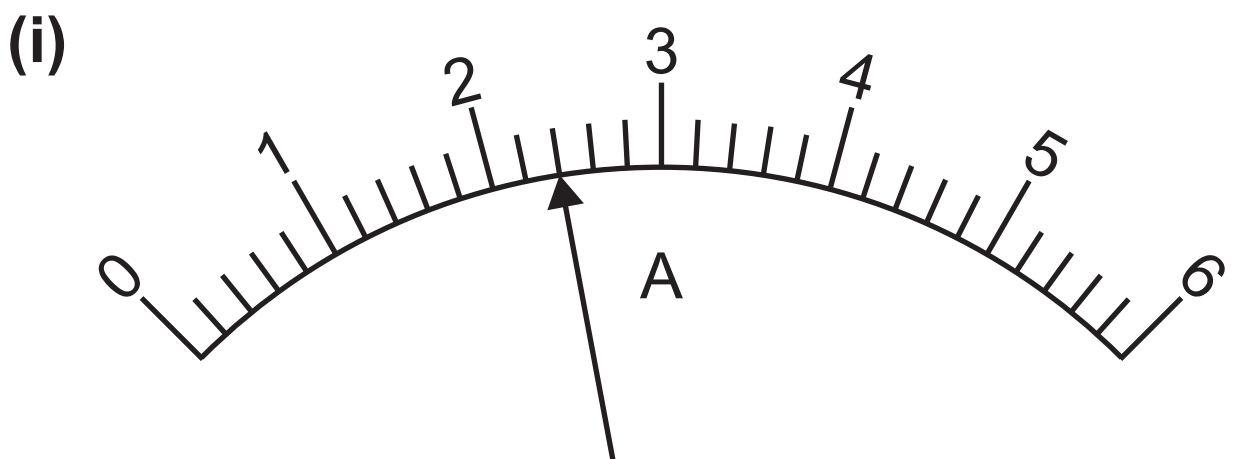
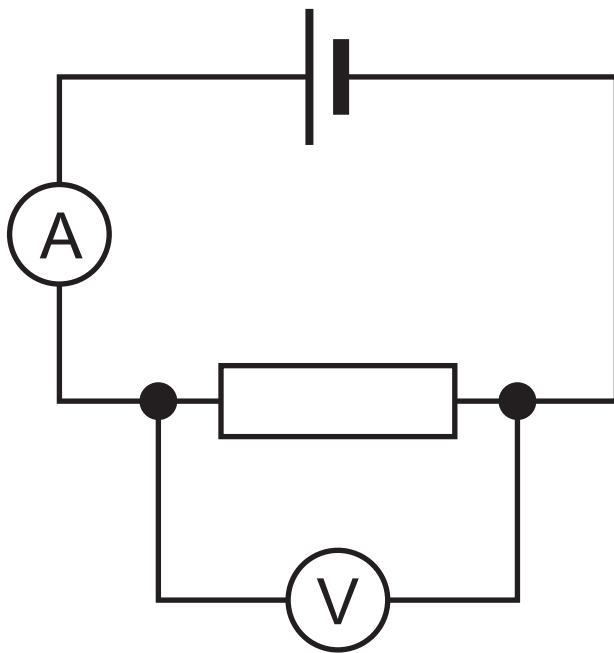

Reading on the ammeter = _____ A

(ii)

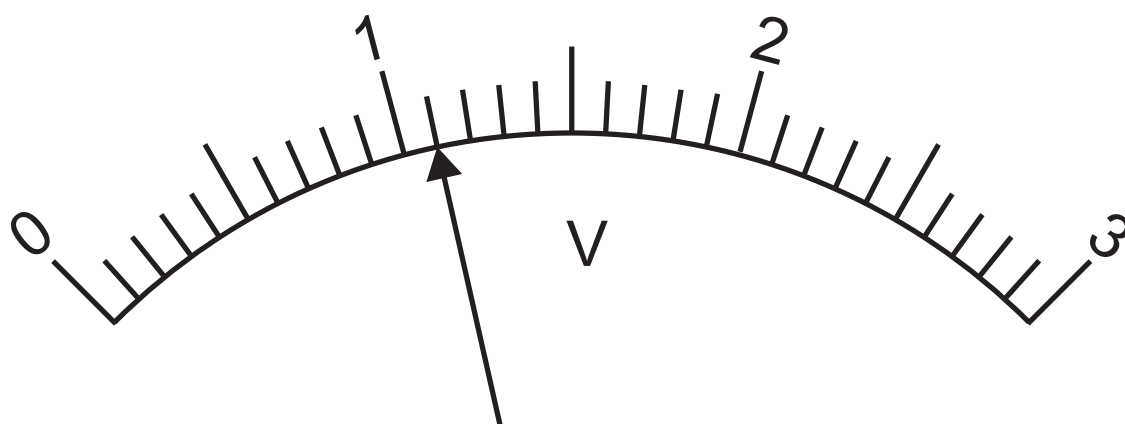

Reading on the voltmeter = _____ V

(iii) Using these readings, calculate the resistance of the resistor. [3 marks]
Show clearly how you get your answer, starting with the equation you plan to use.

Resistance = _____ Ω

(b) (i) Using correct symbols, complete the circuit diagram below to show **two** bulbs connected in series. [1 mark]

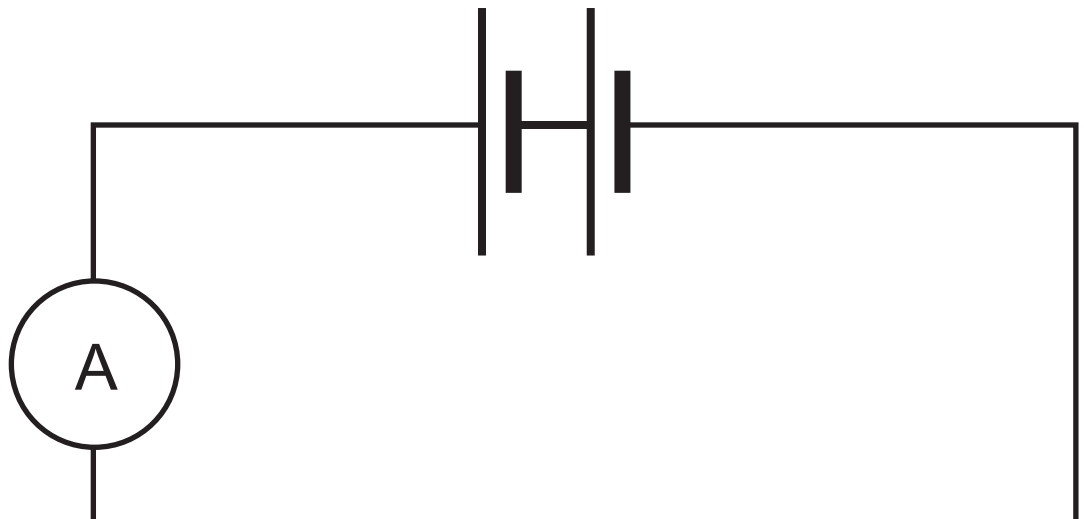

The current was recorded as up to 5 bulbs were connected in series. The measurements are shown on the graph below.

(ii) Label each axis with the quantity and unit if appropriate. [2 marks]

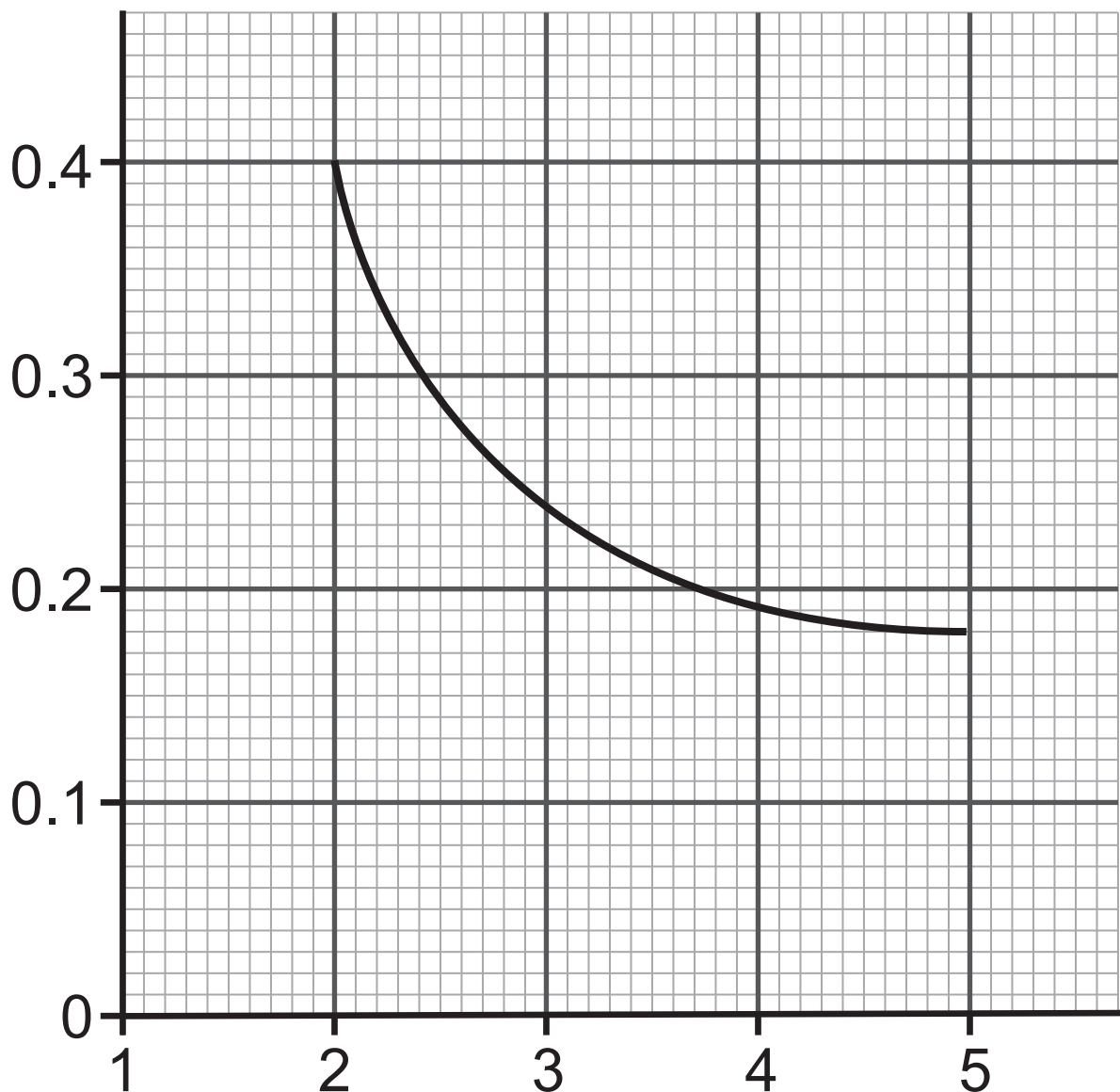

(iii) The current is **not proportional** to the number of bulbs connected in series.

Explain why the graph supports this statement. [1 mark]

The relationship between the current I and N the number of bulbs in series is given by the equation below.

$$I = \frac{V}{N \times r}$$

I = current

V = battery voltage = 3.2 V

N = number of bulbs connected in series

r = resistance of one bulb.

(iv) Using the graph, find the current when **4 bulbs** are connected in series and use this value of current to calculate the value for the resistance of a single bulb. Give your answer to **one decimal place.** [3 marks]
Show clearly how you get your answer.

$r = \underline{\hspace{2cm}} \Omega$

(c) The bulbs that were connected in series are now connected in parallel.

The graph below shows how the current flowing in the circuit changes as the number of bulbs is increased from two to five.

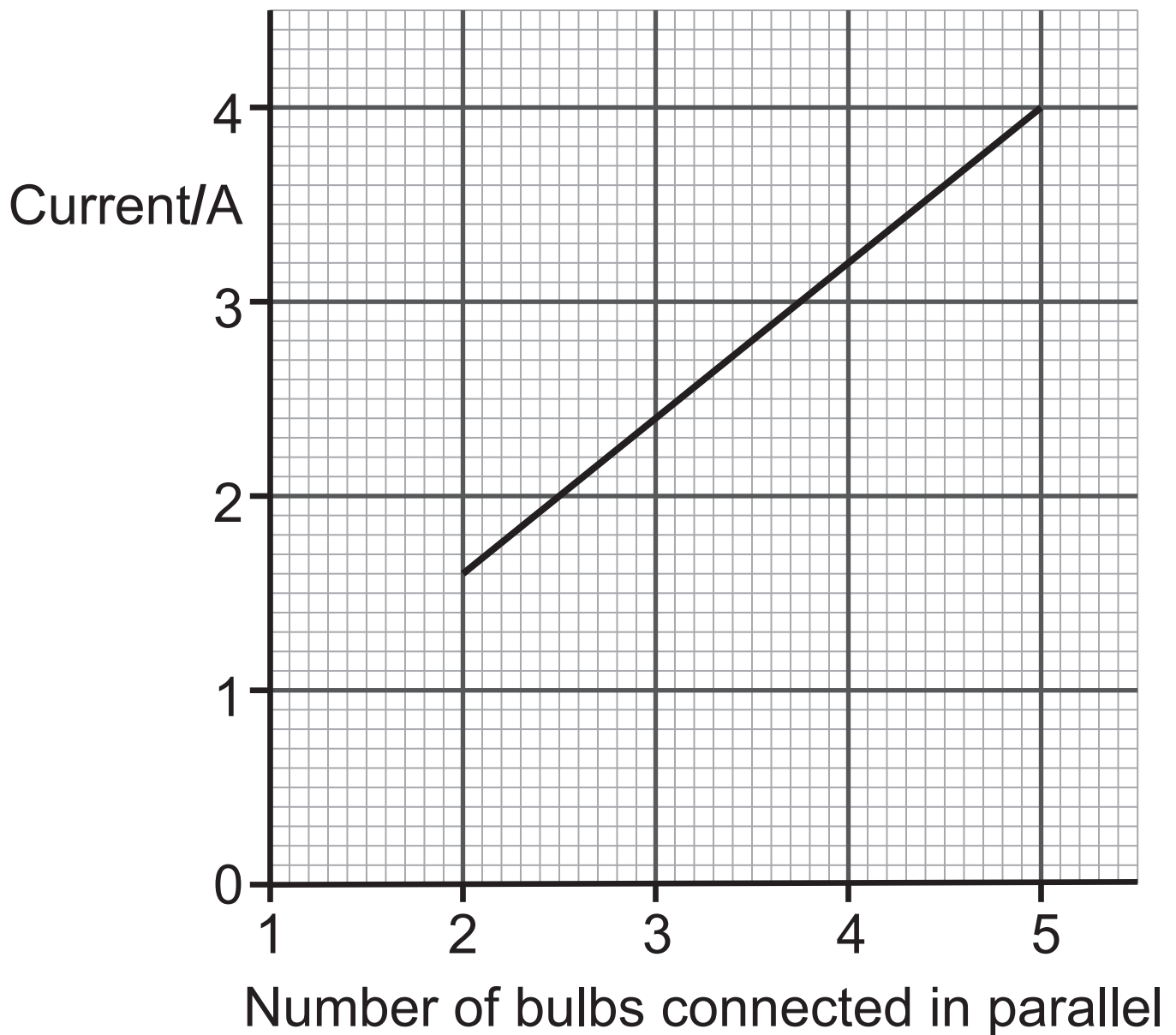

- (i) By extending the straight line, find the current when just one bulb is used.
[1 mark]

Current = _____ A

- (ii) Using this value of the current, calculate the resistance of one bulb.
[2 marks]

The battery used in the circuit has a value of 3.2 V.

Show clearly how you get your answer. Give your answer to one decimal place.

Resistance = _____ Ω

**This is the end of the
question paper**

SOURCES

Q1(a) . . . © *Getty Images*

Q2 © *Getty Images*

Q2(b) . . . © *Principal Examiner*

For Examiner's use only	
Question Number	Marks
1	
2	
3	
4	
Total Marks	

Examiner Number

Permission to reproduce all copyright material has been applied for.
In some cases, efforts to contact copyright holders may have been unsuccessful and CCEA will be happy to rectify any omissions of acknowledgement in future if notified.